

OPTICON

Wireless Barcode Scanner

OPL 7734



The OPL 7734 is a wireless barcode scanner that complies with the IEEE 802.15.4 interface.

Specifications Manual

All information subject to change without notice.

Document History

Model Number:	OPL 7734	Specification Number:	SS08004
Edition:	1A	Original Spec Number:	SS07037
Date:	2008-02-08		

Copyright 2008 Opticon. All rights reserved.

This manual may not, in whole or in part, be copied, photocopied, reproduced, translated or converted to any electronic or machine readable form without prior written consent of Opticon.

Limited Warranty and Disclaimers

PLEASE READ THIS MANUAL CAREFULLY BEFORE INSTALLING OR USING THE PRODUCT.

Serial Number

A serial number appears on all Opticon products. This official registration number is directly related to the device purchased. Do not remove the serial number from your Opticon device. Removing the serial number voids the warranty.

Warranty

Unless otherwise agreed in a written contract, all Opticon products are warranted against defects in materials and workmanship for two years after purchase. Opticon will repair or, at its option, replace products that are defective in materials or workmanship with proper use during the warranty period. Opticon is not liable for damages caused by modifications made by a customer. In such cases, standard repair charges will apply. If a product is returned under warranty and no defect is found, standard repair charges will apply. Opticon assumes no liability for any direct, indirect, consequential or incidental damages arising out of use or inability to use both the hardware and software, even if Opticon has been informed about the possibility of such damages.

Packaging

The packing materials are recyclable. We recommend that you save all packing material to use should you need to transport your scanner or send it for service. Damage caused by improper packaging during shipment is not covered by the warranty.

Trademarks

Trademarks used are the property of their respective owners.

Opticon Inc. and Opticon Sensors Europe B.V. are wholly owned subsidiaries of OPTOELECTRONICS Co., Ltd., 12-17, Tsukagoshi 4-chome, Warabi-shi, Saitama, Japan 335-0002. TEL +81-(0) 48-446-1183; FAX +81-(0) 48-446-1184

SUPPORT

USA

Phone: 800-636-0090

Email: support@opticonusa.com

Web: www.opticonusa.com

Europe

Email: support@opticon.com

Web: www.opticon.com

Contents

1. Abstract	6
2. Overview	6
3. Physical Features	7
3.1. Dimensions	7
3.2. Weight	7
3.3. Color	7
4. Environmental Specifications	8
4.1. Operating Temperature and Humidity	8
4.2. Storage Temperature and Humidity	8
4.3. Ambient Light Immunity	8
5. Controls	9
6. Electrical Specifications	10
6.1. Main Battery	10
6.2. Battery Operating Time and Charging Time	10
6.3. Operating Indicators	11
6.3.1. LED Indicator	11
7. Optical Specifications	11
7.1. Laser Scan Specifications	11
7.1.1. Tilt of Laser Scan Line	11
7.1.2. Curvature of Scan	12
8. Technical Specifications	12
8.1. Print Contrast Signal (PCS)	12
8.2. Minimum Resolution	12
8.3. Scan Area and Resolution	13
8.3.1. Depth of Field	13
8.4. Pitch, Skew, and Tilt	14
8.4.1. Pitch Angle	14
8.4.2. Skew Angle and Dead Zone	15
8.4.3. Tilt Angle	15
8.5. Curvature	16
9. Interface Specifications	17
9.1. Wireless Interface	17

9.2. IEEE 802.15.4	17
9.2.1. Radio Equipment	17
9.2.2. Frequency Band.....	17
10. Default Settings	18
10.1. Set Default Interface	18
10.2. Default Settings 1: Readable Codes	18
10.3. Default Settings 2: Read Options, Trigger, Buzzer	20
10.4. Default Settings 3: Communication Settings	21
10.4.1. Cradle Registration	21
10.4.2. Wireless Adapter OPA 1001 Registration.....	21
10.4.3. Wireless Communication Channel Settings: CH11–CH26	21
10.4.4. Data Memorizing Outside the Communication Range	21
10.5. Default Settings 4: Communication Settings between the Cradle and Host via RS-232C	21
11. Serial Number and Labeling	22
11.1. Serial Number Label	22
11.2. Laser Class Label	22
11.3. Certification Label	22
12. Packaging Specifications	23
12.1. Individual Packaging Specification	23
12.2. Collective Packaging Specification	24
13. Durability	25
13.1. Static Electricity	25
13.2. Shock	25
13.2.1. Drop Test (without packaging)	25
14. Reliability.....	26
15. Regulatory Compliance	26
15.1. Laser Safety	26
15.2. Product Safety.....	26
15.3. EMC	26
15.4. RoHS.....	26
15.5. R&TTE	27
15.6. Radio Law	27
15.7. State of California: Perchlorate Best Management Practices	27
16. Safety	28

16.1. Shock	28
16.2. Temperature Conditions.....	28
16.3. Foreign Materials	28
16.4. Other	28
17. Mechanical Drawings	29

Table of Figures

Figure 1: Ambient light immunity.....	8
Figure 2: Laser scan tilt and curvature	12
Figure 3: Depth of field	13
Figure 4: Pitch	14
Figure 5: Skew and dead zone.....	15
Figure 6: Tilt angle	15
Figure 7: Curvature.....	16
Figure 8: Serial number	22
Figure 9: Laser class label.....	22
Figure 10: Certification label.....	22
Figure 11: Individual packaging	23
Figure 12: Collective packaging.....	24
Figure 13: Drop test.....	25
Figure 14: Mechanical drawing.....	29
Figure 15: Detailed drawing.....	30

1. Abstract

This manual provides specifications for the OPL 7734 wireless barcode scanner.

2. Overview

- The OPL 7734 is a wireless barcode scanner.
- The use of a short-wavelength red laser beam enhances visibility when scanning lines. Press the trigger key without allowing the optical window of the scanner to touch the barcode.
- Feature settings can be configured by scanning menu barcodes or by sending appropriate commands.
- Scanned data can be transmitted to the host through wireless communication (complies with IEEE802.15.4) using a dedicated communication cradle. The scanner is supplied with a IEEE 802.15.4 dongle to establish wireless communication through the USB port of hosting hardware. When the scanner is outside the wireless communication range, scanned data can be stored in the embedded memory.
- The scanner's lithium-ion battery can be charged by setting the scanner in a dedicated cradle (CRD 7722 or CRD 7734).
- The OPL 7734 complies with RoHS.

Supported symbologies:

Linear (1D)

JAN/UPC/EAN, incl. add-on
Codabar/NW-7
Code 11
Code 39
Code 93
Code 128
GS1-128 (EAN-128)
GS1 Databar (RSS)
IATA
Industrial 2of5
Interleaved 2of5
ISBN-ISMN-ISSN
Matrix 2of5
MSI/Plessey
S-Code
Telepen
Tri-Optic
UK/Plessey

Postal

Chinese Post
Korean Postal Authority Code

2D

Composite Codes

3. Physical Features

3.1. Dimensions

W 55.0 x D 115.0 x H 150.0 mm

3.2. Weight

130 g (max.) including the battery

3.3. Color

Black

4. Environmental Specifications

4.1. Operating Temperature and Humidity

Temperature: 0 to 40° C

Humidity: 25 to 85%

4.2. Storage Temperature and Humidity

Temperature: -20 to 60° C

Humidity: 20 to 90%

4.3. Ambient Light Immunity

Decoding performance is guaranteed when the range of illumination on a barcode surface is between zero and the following values:

Incandescent light	3,000 lx
Fluorescent light	3,000 lx
Sunlight	50,000 lx

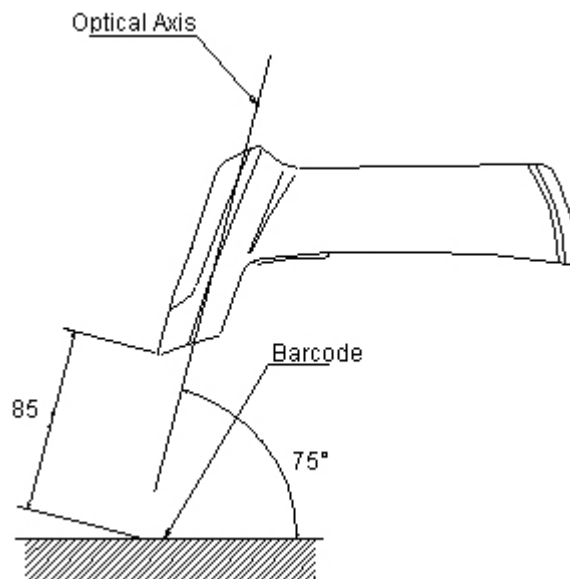

Figure 1: Ambient light immunity

Conditions

Barcode Sample: OPTOELECTRONICS Test Sample

PCS:	0.9
Resolution:	0.25 mm
Symbology:	8-digit Code 39
Quiet zone:	10 mm
N/W ratio:	1:2.5
Distance:	150 mm
Angle (see note below):	$\alpha = 0^\circ \beta = 15^\circ \gamma = 0^\circ$
Curvature:	$R = \infty$

Direct light or specular reflection from a light source should be prevented from entering the acceptance area.

Note: α , β and γ respectively represent pitch, skew and tilt. Please see section 8 for how these values are defined.

5. Controls

Item	Specifications	Notes
CPU	16 bits CMOS CPU	
Clock frequency	14.74 MHz	
External memory	FROM 256 KB SRAM 32 KB (no backup)	for BIOS/AP/DATA for WORK/DATA
Operation	Operation keys: 1 key (trigger and transmit) Maximum scans: 500,000 times	
Display LED	Bi-color LED (red and green)	

6. Electrical Specifications

6.1. Main Battery

The main battery is a lithium-ion secondary battery.

Nominal capacity: 600 mAh

Nominal voltage: 3.7 V

6.2. Battery Operating Time and Charging Time

Parameter	Specification	Note
Battery life	300 cycles of charge and discharge	Capacity 70% filled 1 C charge and discharge
Usable time	50 hours or more	1 scan/5 s Barcode sample: 9-digit Code 39, PCS 0.9, Resolution: 0.25 mm
Current consumption	1 mA or less 35 mA or less 125 mA or less	In standby state In wireless communication Max. consumption
Operating conditions	Temperature: +25° Scan a barcode once in every 5 seconds Barcode sample: 9-digit Code 39, PCS: 0.9, Resolution: 0.25 mm	
Charging time	2 ½ hours	Time necessary to fully charge the battery at the operating temperature of 25°

Note: Battery life may be shorter than specified above when the quality of the battery pack is degraded.

6.3. Operating Indicators

The OPL 7734 uses an LED and buzzer to indicate its status.

6.3.1. LED Indicator

State	Color	Display	Operation State
Charging	Red	Lighting	When the scanner is set in the cradle, this LED shows that the scanner is being charged.
	Green	Lighting	The light changes to green from red when the charging operation is completed
Scanning	Green	Blinking	Shows the successful completion of scanning or data transmission.
	Red	Blinking	Shows that the data could not be transmitted.
	Orange	Blinking	Shows that the data is being stored in the memory.
Wireless Connection	Green	Lighting	Shows the completion of registration.
	Red	Lighting	Shows that the registration failed.

7. Optical Specifications

7.1. Laser Scan Specifications

Parameter	Specification	Unit
Light-emitting element	Red laser diode	—
Emission wavelength	650 ±10 (25° C)	nm
Light output	1.0 or less	mW
Scanning method	Bi-directional scanning	—
Scanning speed	100 ±20	scans/s
Scan angle	Scan angle: 54 ±5	°
	Read angle: 44 (Min)	°

Notes:

Refer to chapter 8, “Technical Specifications,” to read about scanning performance.

7.1.1. Tilt of Laser Scan Line

Maximum tilt between both ends of laser scan line: Less than 1.2° upward tilt from the scan origin.

Maximum of 3.1 mm when measured at a point 150 mm away from the scan origin. (The skew angle of this measurement was zero degrees.)

Measurement was done from the center of scan line.

7.1.2. Curvature of Scan

Maximum gap between the straight line connecting both ends of the laser scan line and the actual laser scan line: Less than 1.27° curvature from the scan origin.
Maximum of 3.3 mm curvature when measured at a point 150 mm away from the scan origin. (The skew angle of this measurement was zero degrees.)
Measurement was done from the center of scan line.

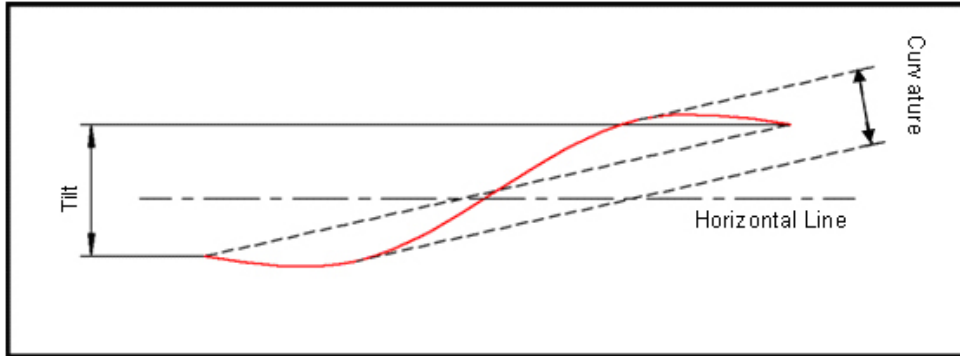

Figure 2: Laser scan tilt and curvature

8. Technical Specifications

The conditions for technical specifications are as follows, unless otherwise specified in each section.

Conditions

Ambient temperature and humidity:	Room temperature (5 to 35° C) Room humidity (45% to 85% RH)
Ambient light:	500 to 900 lx
Background:	Barcode = black Space = white Margin = white Background of label = black
Decoding test:	Approve the performance when decoding is successful in all ten tests. (Decoding is deemed successful when completed in 0.5 seconds or less.)

8.1. Print Contrast Signal (PCS)

0.45 or higher (over 70% of reflectivity of space and quiet zone).

$$PCS = \frac{\text{Reflectance of white bar} - \text{Reflectance of black bar}}{\text{Reflectance of white bar}}$$

Scanning performance may decline if dirt or scratches mar the optical window. Keep the optical window clean.

8.2. Minimum Resolution

0.15 mm

8.3. Scan Area and Resolution

8.3.1. Depth of Field

The depth of field is measured from the edge of the scanner. The scanning range is within the circular arc centered on the scan origin.

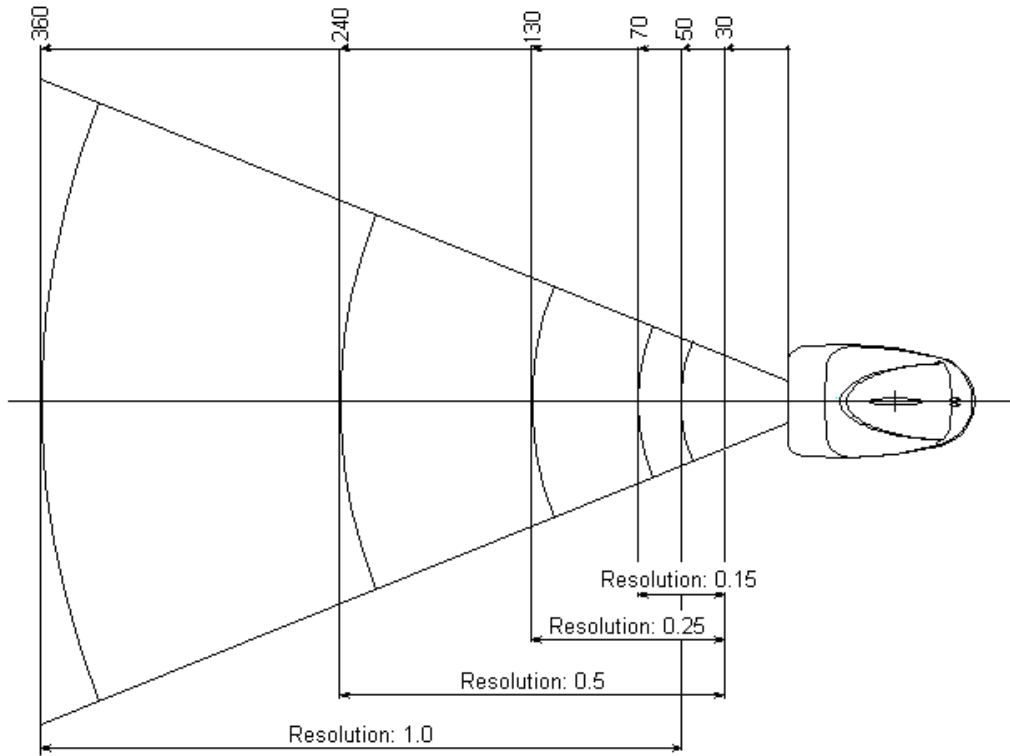

Figure 3: Depth of field

Symbology	Resolution (mm)	Decode Depth (mm)	PCS
Code 39	1.0	50–360	0.9
Code 39	0.5	30–240	0.9
Code 39	0.25	30–130	0.9
Code 39	0.15	30–70	0.9

Conditions

Barcode Sample: OPTOELECTRONICS Test Sample

- N/W ratio: 1:2.5
- Angle: $\alpha = 0^\circ, \beta = 15^\circ, \gamma = 0^\circ$
- Curvature: $R = \infty$

Resolution	Symbology	PCS	Quiet Zone	Digit
1.0 mm	Code 39	0.9	25 mm	1
0.5 mm	Code 39	0.9	18 mm	3
0.25 mm	Code 39	0.9	10 mm	8
0.15 mm	Code 39	0.9	7 mm	10

8.4. Pitch, Skew, and Tilt

8.4.1. Pitch Angle

$\alpha = \pm 20^\circ$

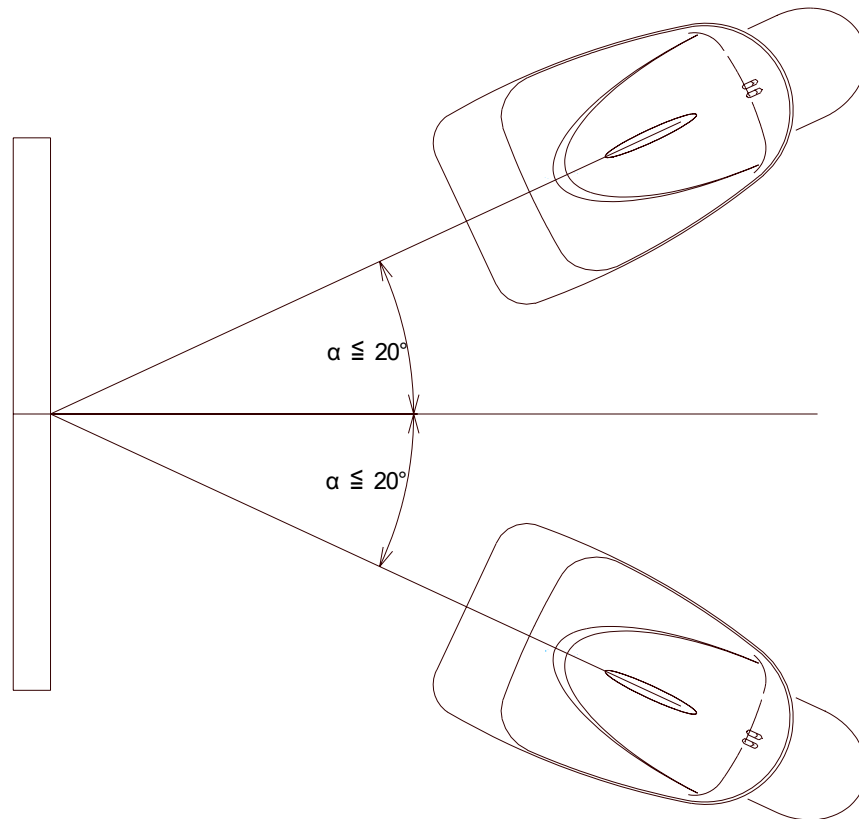

Figure 4: Pitch

8.4.2. Skew Angle and Dead Zone

Skew angle: $\beta = \pm 50^\circ$ (Excluding dead zone)

Dead zone: $\beta = \pm 8^\circ$ (There are some areas in which decoding fails due to specular reflection)

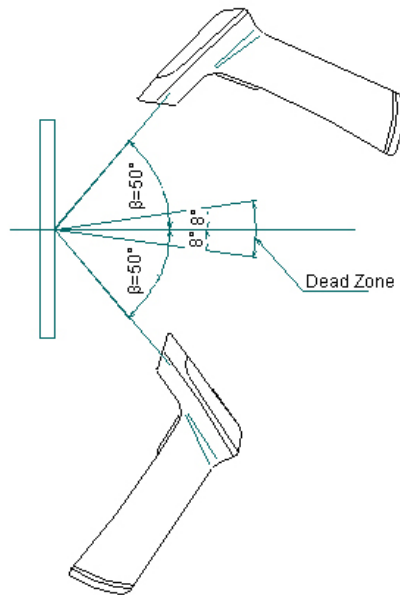

Figure 5: Skew and dead zone

8.4.3. Tilt Angle

$\gamma = \pm 20^\circ$

Scanning performance is guaranteed up to $\gamma < \pm 20^\circ$ in the clockwise rotation and counterclockwise rotation.

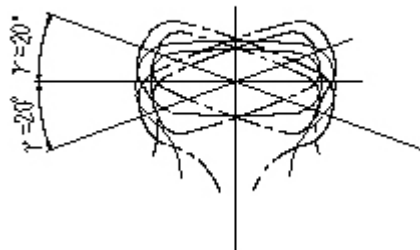

Figure 6: Tilt angle

Conditions

Barcode Sample: OPTOELECTRONICS Test Sample

PCS = 0.9, Resolution = 0.26 mm, Symbology = 13-digit JAN

8.5. Curvature

With 8-digit JAN/UPC/EAN barcodes, decoding performance is guaranteed when $R \geq 15$ mm.

With 13-digit JAN/UPC/EAN barcodes, decoding performance is guaranteed when $R \geq 20$ mm.

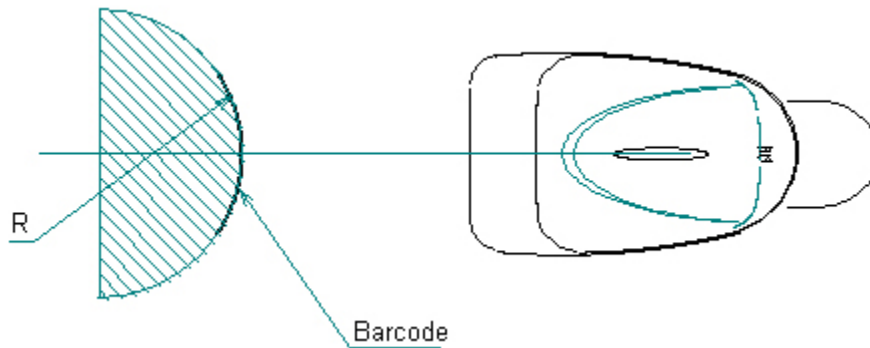

Figure 7: Curvature

Conditions

Barcode Sample: OPTOELECTRONICS Test Sample

PCS = 0.9, Resolution = 0.26 mm

9. Interface Specifications

9.1. Wireless Interface

Item	Specification	Notes
Frequency	2400 MHz to 2483.5 MHz	
Communication specification	IEEE 802.15.4 compliant	
Transmission power	0 dBm or less	
Communication distance	30 m	Depends on the environment.
Baud rate	115.2 Kbps	
Antenna	1/4λ surface-mounted type	
Communication configuration	1 CRD 7734 cradle to a maximum of 8 scanners	
Operation mode during wireless communication	Peer to peer	
Encryption	Encryption is available.	

9.2. IEEE 802.15.4

9.2.1. Radio Equipment

The electromagnetic wave absorption (2.4 GHz) used by this product is also shared by various other devices. Therefore, baud rate and communication distance may be negatively impacted, or their communications may be disconnected, by other devices using the same absorption rate.

Baud rate and communication distance are affected by obstacles, wave conditions, or a device at the other end.

This product is equipped with an antenna. Bringing this product too close to a metallic object may affect communication. Anticipated interference distance is 10 m or less.

9.2.2. Frequency Band

This product uses the 2.4 GHz frequency band. Scientific, medical, and industrial devices, including microwaves, wireless security (camera) systems and W-LAN use the same frequency band as this scanner. Other radio stations also use this frequency for mobile object identification, including local private radio stations that require a license (for example, manufacturing lines at factories), specific power-saving radio stations requiring no license, and amateur radio stations.

Interference from other devices may affect the communication speed or communication range of this scanner or vice versa.

10. Default Settings

10.1. Set Default Interface

To make it easier to configure the reading and communication settings of the OPL 7734, a default setting set [U1] is available. OPL 7734 scanners are configured to [U1] when shipped.

[U1] Settings: CRD 7734 Default Settings

Functions	Menu labels	Menu codes
SET		ZZ
Default Setting: CRD 7734 connection		U1
END		ZZ

[C02] Settings: OPA 1001 Default Settings

Functions	Menu labels	Menu codes
SET		ZZ
Default Setting: OPA 1001connection		C02
END		ZZ

10.2. Default Settings 1: Readable Codes

Symbology	Read	Transmit Code Length	Transmit CD	Calculate CD	Set Prefix	Set Suffix	Other
UPC-A	■	X	■	■	—	CR	
UPC-A Add-on	X	X	■	■	—	CR	
UPC-E	■	X	X	■	—	CR	
UPC-E Add-on	X	X	X	■	—	CR	
EAN-13	■	X	■	■	—	CR	
EAN-13 Add-on	X	X	■	■	—	CR	
EAN-8	■	X	■	■	—	CR	
EAN-8 Add-on	X	X	■	■	—	CR	
Chinese Post 2of5	X	X	■	X	—	CR	
Codabar / NW-7	■	X	X	X	—	CR	Not transmit ST/SP

Symbology	Read	Transmit Code Length	Transmit CD	Calculate CD	Set Prefix	Set Suffix	Other
Code 11	X	X	X	■	—	CR	
Code 39	■	X	■	X	—	CR	Not transmit ST/SP
Code 93	X	X	X	■	—	CR	
Code 128	X	X	X	■	—	CR	
GS1-128 (EAN/UCC-128)	X	X	X	■	—	CR	
GS1 DataBar (RSS)	X	X	■	■	—	CR	
IATA	X	X	■	X	—	CR	
Industrial2of5	■	X	■	X	—	CR	
Interleaved2of5	■	X	■	X	—	CR	
Korean Postal Code	X	X	X	■	—	CR	
MSI/Plessey	X	X	■CD1	■CD1	—	CR	
UK/Plessey	■	X	■	■	—	CR	
S-Code	■	X	■	X	—	CR	
Telepen	■	X	X	■	—	CR	
Tri-Optic	■	X	—	—	—	CR	Not transmit ST/SP

Notes:

In the "Reading" column, "■" means "Enable reading" and "X" means "Disable reading."

In the "Transmit code length" column, "■" means "Transmit code length" and "X" means "Do not transmit code length."

In the "Transmit CD" column, "■" means "Transmit check digit" and "X" means "Do not transmit check digit."

In the "Calculate CD" column, "■" means "Calculate check digit" and "X" means "Do not calculate check digit."

"—" means "not supported." In the "Prefix" column, "—" means "there is no prefix setting."

10.3. Default Settings 2: Read Options, Trigger, Buzzer

Item	Default Setting
Setting the number of characters	Fixed length OFF all codes
Read mode	Single read
Multiple read reset time	500 ms
Add-on wait mode	500 ms
Multiple column read	Disable
Redundancy	Read 3 times, redundancy = 2
Intercharacter gap check	Within 1 character gap
Manual trigger	Enable
Read time	2 seconds
Buzzer duration	200 ms
Buzzer tone	3 kHz + 2.5 kHz
Buzzer loudness	Loud (70 dBA or more at maximum loudness), 10 cm from the front edge
Indicator duration	200 ms

10.4. Default Settings 3: Communication Settings

10.4.1. Cradle Registration

Scan the device address barcode printed on a label attached to the bottom of the communication cradle. It determines which cradle to communicate with. This registration needs to be done in order to transmit scanned data.

10.4.2. Wireless Adapter OPA 1001 Registration

Scan the device address barcode printed on a label attached to the bottom of the Wireless Adapter OPA 1001. It determines which cradle to communicate with. This registration needs to be done in order to transmit scanned data.

10.4.3. Wireless Communication Channel Settings: CH11–CH26

The wireless communication channel settings can be selected.

10.4.4. Data Memorizing Outside the Communication Range

Selecting “Data Memorizing Enabled” allows the scanner to read data outside the communication range and store the data in the memory of the OPL 7734. When the scanner returns to the communication range again, it will be re-connected and the temporary stored data will automatically be transmitted to the host.

Note: When selecting “Data Memorizing Disabled,” the scanner will not read data outside the range.

Items	Settings
Cradle registration	Disable
Data memorizing settings	Enable
Wireless communication channel settings	CH15
Encryption	Enable

10.5. Default Settings 4: Communication Settings between the Cradle and Host via RS-232C

Parameter	Setting	Menu Command
Baud rate	9600 bps	K6
Data bits	8 bits	L1
Parity	No parity	L2
Stop bit	1 stop bit	L5
Handshaking	Busy/ready	P0
ACK/NAK	No response	P5
Flow control time out	Indefinitely	I0

11. Serial Number and Labeling

11.1. Serial Number Label

The serial number shown below is affixed to the scanner.



Figure 8: Serial number

11.2. Laser Class Label

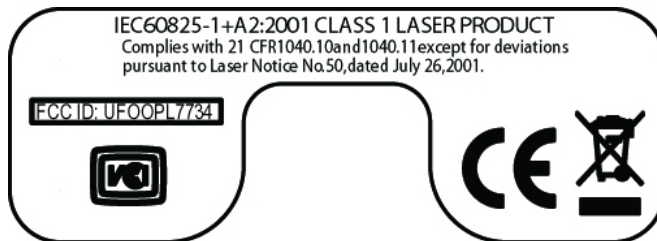

Figure 9: Laser class label

11.3. Certification Label



Figure 10: Certification label

12. Packaging Specifications

12.1. Individual Packaging Specification

Put the scanner in a protective foam bag and place it in an individual packing box.

Size of the package after assembly: (W) 245 x (D) 110 x (H) 80 mm

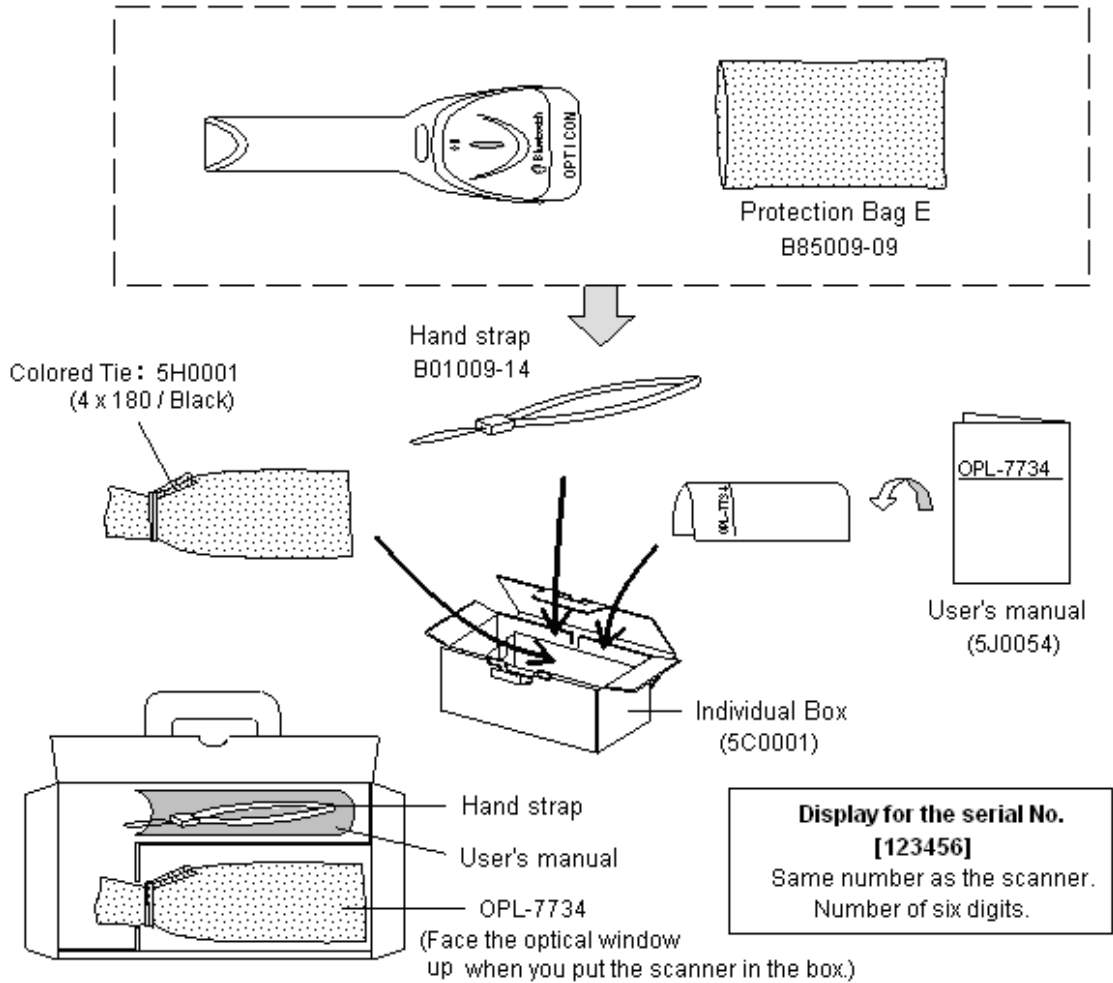

Figure 11: Individual packaging

12.2. Collective Packaging Specification

Size of the package after assembly: (W) 580 x (D) 505 x (H) 450 mm

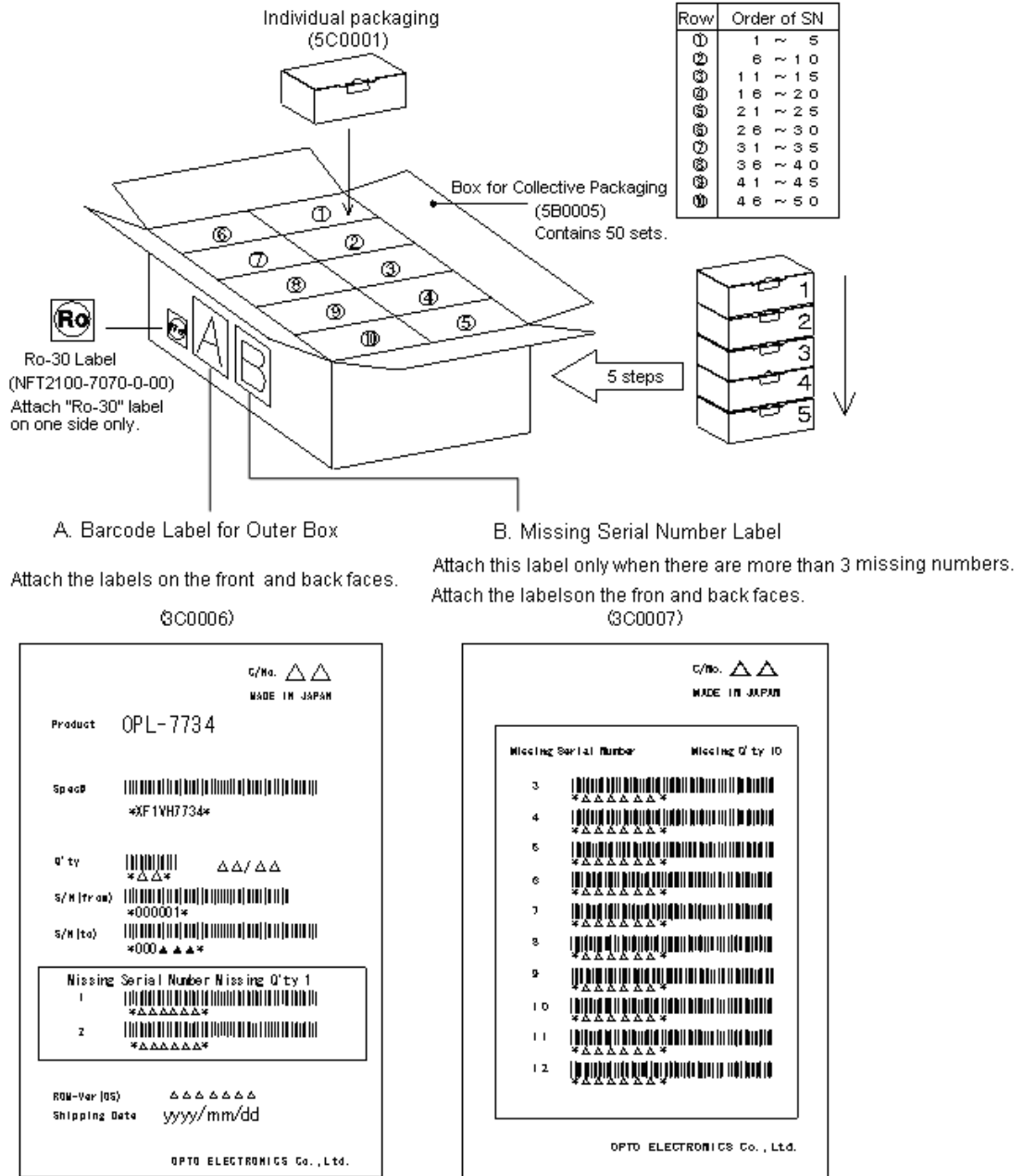

Figure 12: Collective packaging

Note: The “RO” mark labeled on the package tray or package box guarantees that the applicable product has passed our test of RoHS restrictions compliance (the restriction of the use of certain hazardous substances in electrical and electronic equipment, 2002/95 EC). However, this document does **not** have any legal weight in the European Union.

13. Durability

13.1. Static Electricity

Air discharge (No malfunction): ± 8 kV max.

Air discharge (No destruction): ± 15 kV max.

Indirect discharge (No malfunction): ± 8 kV max.

Conditions

Measurement environment:	Use electrostatic testing device compliant with IEC 61000-4-2 Built up and discharged 15 kV of static electricity on the scanner surface 50 times.
Discharge resistance:	330 Ω
Capacitor charging:	150 pF

13.2. Shock

13.2.1. Drop Test (without packaging)

No malfunction occurred after the following drop test.

Drop Test: Drop the scanner from a height of 150 cm onto a concrete floor (three times in each of 6 sides).

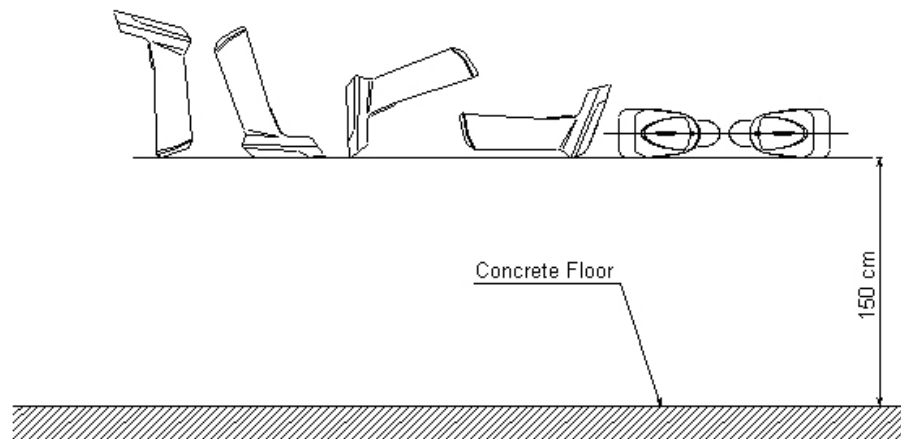

Figure 13: Drop test

Conditions of the drop test are as follows:

- The scanner passes this test even when it is found with minor dents or scratches.
- The scanner passes this test if grip end of the scanner has not fallen apart.

14. Reliability

MTBF (Mean Time Between Failures) of the part of this product that carries current full time is 90,300 hours.

The life cycle of the laser scan engine (without full-time energization) is 10,000 hours.

The life cycle of the trigger key is 500,000 uses.

The estimate of MTBF and product life cycle is based on standard operation of the product within the recommended temperature range and without extreme electronic or mechanical shock.

The MTTR (Mean Time To Repair) of this product is one hour.

15. Regulatory Compliance

15.1. Laser Safety

The scanner emits laser beams.

JIS C6802: 2005: Laser class 1

FDA CDRH Laser class I. Complies with 21 CFR 1040.10 and 1040.11 except for deviations pursuant to laser notice No. 50 dated June 24, 2007.

Class I laser devices are not considered to be hazardous when used for their intended purpose. Avoid staring into the laser beam.

15.2. Product Safety

IEC60950-1: 2001

15.3. EMC

VCCI Class B: This is a Class B product, to be used in a domestic environment based on the Technical Requirement of the Voluntary Control Council for Interference from Information Technology Equipment (VCCI). If this is used near a radio or television receiver in a domestic environment, it may cause radio interference. Please install and use the equipment according to the instruction manual.

FCC Part 15 Subpart B Class B: This device complies with part 15 of the FCC Rules. Operation is subject to the following two conditions: (1) this device may not cause harmful interference, and (2) this device must accept any interference received, including interference that may cause undesired operation.

15.4. RoHS

RoHS: The restriction of the use of certain hazardous substances in electrical and electronic equipment, 2002/95 EC.

15.5. R&TTE

This scanner conforms to the following standards of the Radio and Telecommunications Terminal Equipment (R&TTE) directive from the EU.

EN300 328

IEC60950-1

15.6. Radio Law

The scanner qualifies as radio equipment for low-power radio stations (2.4 GHz band advanced data communication systems) as specified in the Radio Law 38-24-1.

The scanner has obtained the Certification for Construction Design of Specified Radio Equipment. It does not have a radio station license in Japan.

The following activities are prohibited under the Radio Law:

- Remodeling and disassembly
- Peeling off the certificate label

15.7. State of California: Perchlorate Best Management Practices

The batteries on some Opticon products may contain Perchlorate. To comply with California Perchlorate Best Practice Regulations and the Law for the Promotion of Utilization of Recyclable Resources (Japan), products that may contain Perchlorate materials should be properly labeled on the exterior of all outer shipping packages and/or in locations that otherwise satisfy the California Perchlorate Best Management Practices.

16. Safety

Handle this product carefully. Do not deliberately subject it to any of the following.

16.1. Shock

Do not throw or drop the scanner.

Do not drop or put heavy items on this product or its cable.

16.2. Temperature Conditions

Do not use the scanner at temperatures outside the specified range.

Do not use near heat sources such as radiators, heat registers, stoves, or other types of devices that produce heat.

Do not use in areas exposed to direct sunlight for long periods of time.

Do not pinch or forcibly bend the cable, especially at very low temperature.

16.3. Foreign Materials

Do not use the scanner near water or other liquids, as well as in extremely high humidity.

Do not immerse the scanner in liquids.

Do not use in dusty environments.

Do not subject the scanner to chemicals.

Do not insert foreign substances into the device.

16.4. Other

Do not plug/unplug the connectors before disconnecting the power.

Do not attempt to disassemble, modify or update this device.

Do not use near microwaves, medical devices, or RF-emitting devices.

The scanner may not perform properly in environments when placed near a flickering light, such as a computer monitor, television, etc. Do not use in the reach of blinking lights such as CRT.

The scanner may be damaged by voltage drops.

17. Mechanical Drawings

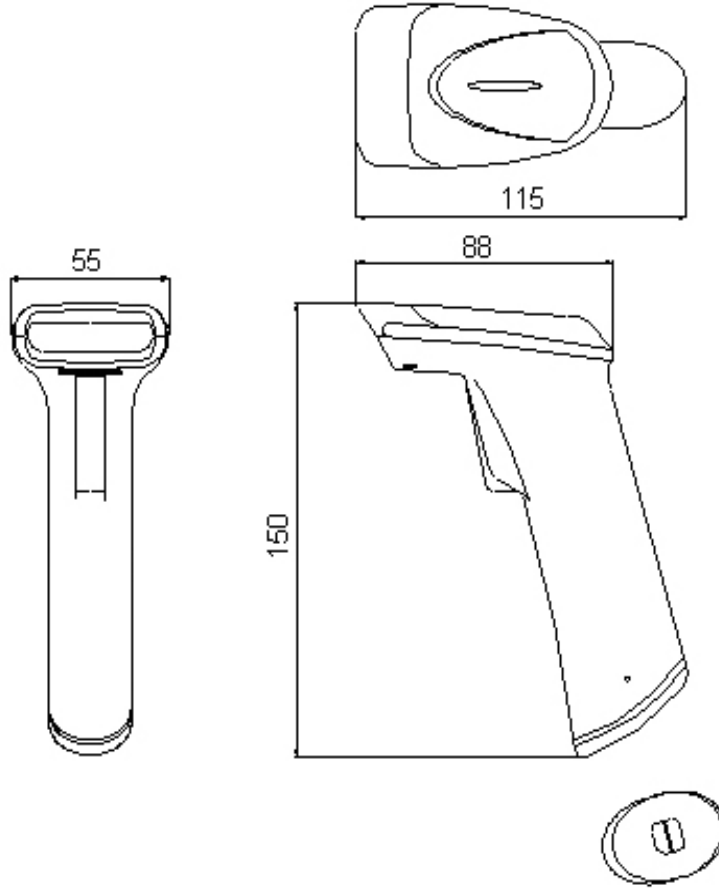

Figure 14: Mechanical drawing

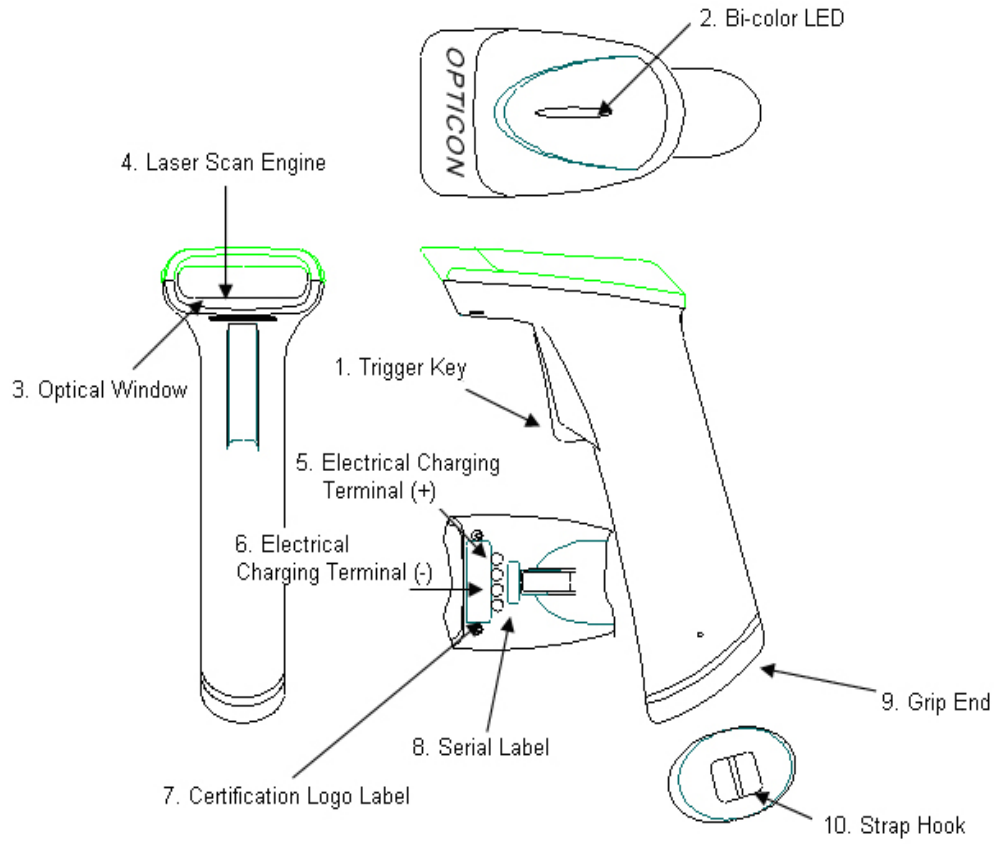

Figure 15: Detailed drawing